

Electrochlorination Systems **CECHLO®**

CECHLO® Electrochlorination systems unite the global electrochlorination leadership of De Nora Water Technologies and the technology know-how of De Nora Permelec Ltd, in Japan; leveraging the combined global assets, resources and capabilities of two recognized leaders in electrochemical technologies. CECHLO® is a well-established product line in Japan which was developed for more than 40 years and is now owned by De Nora Water Technologies.

Introduction

Marine biofouling is a common occurrence in many industrial facilities that use seawater as cooling water or heat source. Electrochlorination systems use a simple and straight forward process, combining three common consumables (salt, water and electricity) to generate sodium hypochlorite for biofouling control as well as for disinfection, bleaching and deodorizing purposes.

This overall chemical reaction can be expressed as follows:

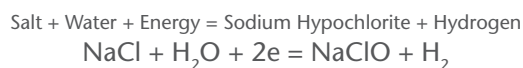

Chlorine or sodium hypochlorite is generally used as a water disinfectant with the regulation of residual chlorine levels at water tap exit by the Water Supply Law in Japan. However, the purchase, handling and storage of liquefied chlorine and commercially available sodium hypochlorite come with associated risks like leakages or explosions occurring during transportation or storage.

CECHLO® electrochlorination system is a safe and economical solution ideally suited for wash disinfection with low risk of handling hazardous chemicals. CECHLO® electrochlorination system has 4 models generating sodium hypochlorite at low strength like 1000 ppm for biofouling control in with seawater electro-chlorination and 0.8%~12.5% of sodium hypochlorite solution for water disinfection, sewage treatment, industrial wastewater oxidation, bleach manufacturing, etc. We can select the most suitable model and design made-to-order according to your request.

There are four types of De Nora CECHLO® systems depending on the concentration of sodium hypochlorite:

Generator type (Electrochlorination Plant)		Concentration	Production Capacity
Brine Electrolysis	CECHLO®-MS	5~12% as Cl ₂	100 kg/d as Cl ₂ ~
	CECHLO®-IS	5% as Cl ₂	50 kg/d as Cl ₂ ~
	CECHLO®-NS	0.8%~1.2% as Cl ₂	1 kg/d as Cl ₂ ~
Seawater/Wastewater Electrolysis	CECHLO®-M	0.01~0.25% as Cl ₂ 100~2,500 ppm	0.5 kg/h as Cl ₂ ~

Ion Exchange Membrane Electrolyzer

CECHLO®-MS

On-Site Hypochlorite Generator (OSHG)/ On-Site Chlorine Generator (OSCG)

Upon application of direct-current electricity, chlorine gas is formed at the anode and caustic soda at the cathode which react in the reactor tower, generating sodium hypochlorite at 12.5% strength. CECHLO®-MS could be the best alternative to Chlorine Gas container and commercial bulk hypochlorite.

Features & Benefits

- No risks associated with delivery or storage of hazardous chemicals such as high-pressure chlorine
- No need to assign qualified staff required by law to handle hazardous chemicals resulting in cost savings
- Low production costs and Low power requirements
- Special metal electrode resulting in high performance
- Robust and durable
- Low operational costs



Applications

- Water/Wastewater Treatment
- Industrial Wastewater Treatment
- Bleach Manufacturing
- Chemical Industries
- Bulk Chemicals
- Chemical Manufacturing

Basic Process Flow

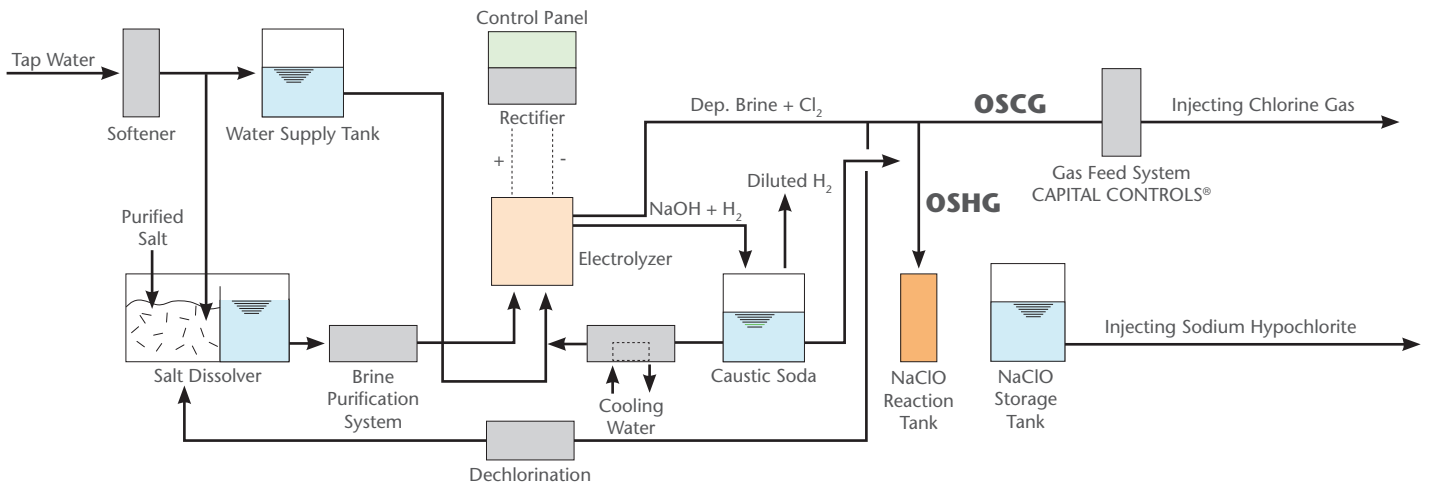

Ion Exchange Membrane Electrolyzer

CECHLO®-IS

On-Site Hypochlorite Generator (OSHG)

Upon application of direct-current electricity, chlorine gas is formed at the anode and caustic soda at the cathode, then generating sodium hypochlorite at 5% strength. CECHLO®-IS can generate sodium hypochlorite on-site at 5% strength from the electrolyzer. If any strict regulation of handling Chlorine Gas, CECHLO®-IS could be the best solution for high strength 5% sodium hypochlorite on-site.

Basic Process Flow

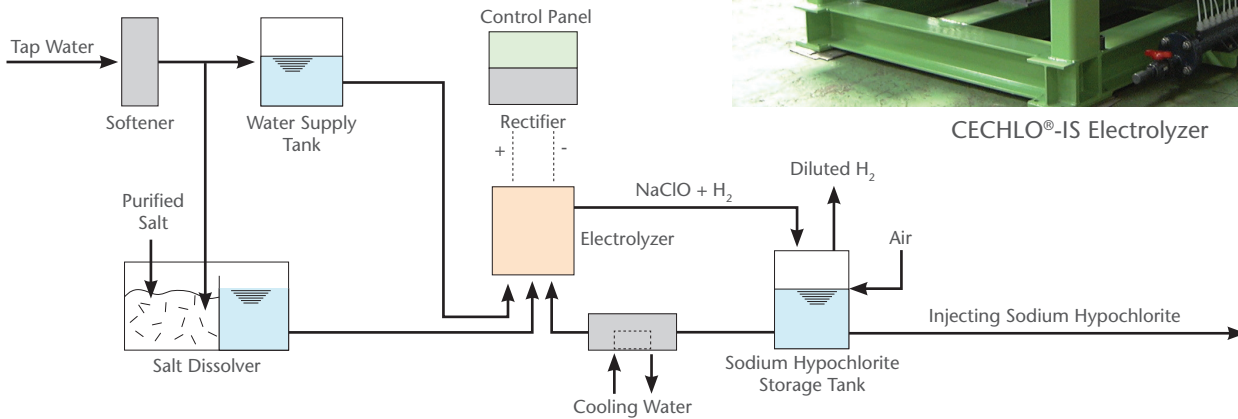

CECHLO®-IS Electrolyzer

Using Direct Electrolysis of Brine Water

CECHLO®-NS

On-Site Hypochlorite Generator (OSHG)

The salt is dissolved in the salt dissolver and the saturated brine is diluted into 3% concentration. Upon the application of direct-current electricity, chlorine gas is generated at the anode and caustic soda at the cathode. Then they react with each other instantly in the electrolyzer and then sodium hypochlorite at 0.5% to 1.2% strength is generated.

Basic Process Flow

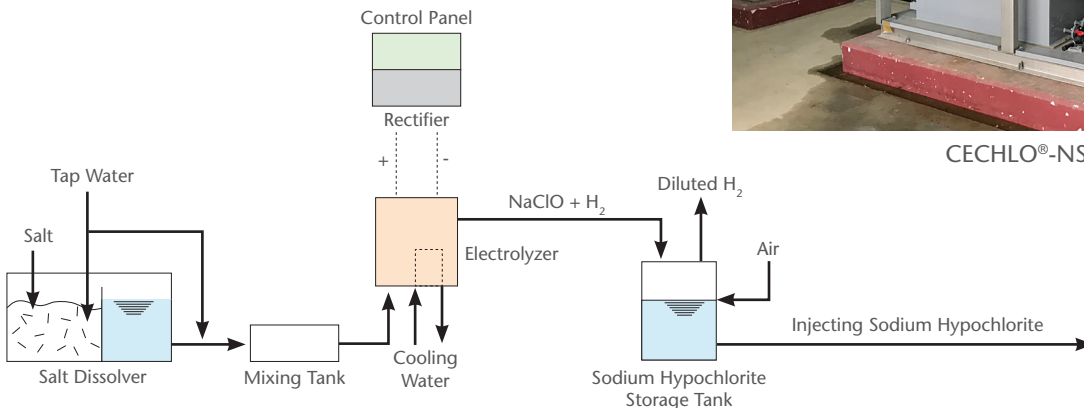

CECHLO®-NS Electrolyzer

Seawater/Wastewater Electro-chlorination

CECHLO®-M

On-Site Hypochlorite Generator (OSHG)

CECHLO®-M system is ideal for small - medium size requirements and can be easily customized due to the system's unique modularized cell design. The NaCl dissolved in the seawater/wastewater is dissociated into Na⁺ and Cl⁻. When fed into the electrolyzer upon application of direct-current electricity, the chlorine gas is formed at the anode and caustic soda at the cathode which react instantly to generate sodium hypochlorite.

Features & Benefits

- Long reliable warranty
- Less frequency of Acid Wash
- DSA® coating
- Titanium cathode
- Bipolar anode/cathode
- Noble metal oxides of platinum group
- Power consumption typically less than 4.5 DC KWh/KGCl₂
- More than 200 installations

Applications

- Thermal Power Plant
- Refinery
- Desalination Plant
- Cooling Tower
- Desalination Plant
- Iron Works
- LNG Terminal
- Nuclear Power Plant
- Offshore Platform
- Petrochemical Plant
- Wastewater Plant

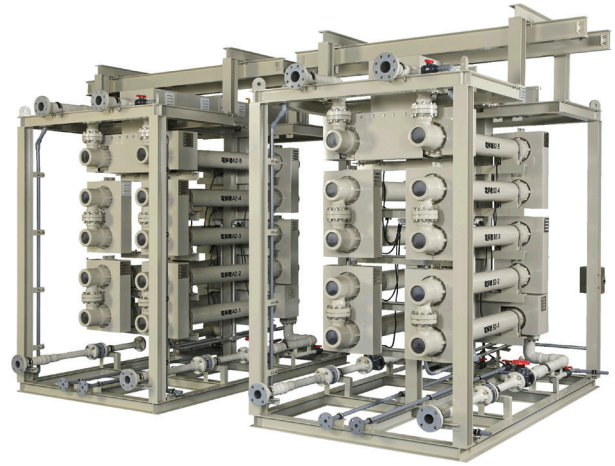

CECHLO®-M Electrolyzer



CECHLO-M SWEC 30kg/hr Power Plant in Japan

Basic Process Flow

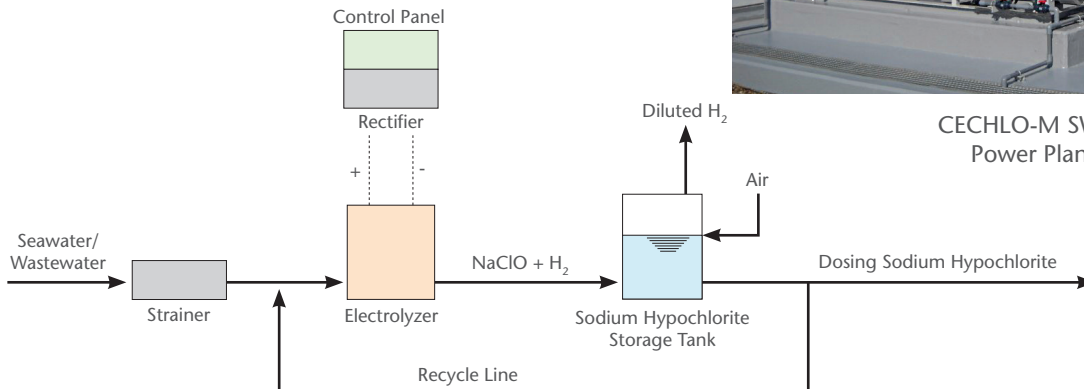

WATER MADE EASY

MARINE

ENERGY

MUNICIPAL

INDUSTRIAL



De Nora Permelec Ltd

Water Technologies Japan
24-6 Higashitakasaki, Tamano-shi, Okayama 706-0134 JAPAN
Tel: +81 863 33 3401 Fax: +81 863 33 3402
Website: www.denora.com

© Copyright 2018 Industrie De Nora S.p.A. - All rights reserved.

De Nora, ON circle, Our research - your future, are trademarks or registered trademarks of Industrie De Nora S.p.A. in Europe and/or other countries. Other trademarks used herein are the registered trademarks of their respective owners.

The information contained herein is offered for use by technically qualified personnel at their discretion and risk without warranty of any kind.

DNWT - CECHLO® Electrochlorination Systems - 750-0130.3 - 10/2018